

Exercise 301

Determination of electrical resistance using Wheatstone bridge

March 23, 2009

The aim of this exercise is to familiarise with a method of determination of electrical resistance based on Wheatstone bridge and measurement of unknown resistances and their combinations.

1 Theoretical prerequisites

1. Ohm's law, Kirchhoff's laws.
2. Physical basis of Wheatstone bridge.
3. Serial and parallel connections of resistors. Calculation of equivalent resistance of series of resistors.

2 Equipment

DC power source, current direction switch, decimal resistor, sliding potentiometer, galvanometer, unknown resistors, electric wires.

3 Measurement method

One of the methods of measuring electrical resistance is application of a Wheatstone bridge (Fig. 1). It consists of resistors R_1 , R_2 , R and an unknown resistor R_x and galvanometer G. The bridge is powered by a DC power supply Z connected through current direction switch K.

In the measurement the ratio R_1/R_2 has to be adjusted to balance the bridge, i. e. to achieve the situation when no current flows through the galvanometer. In such a case it is possible to determine unknown resistance R_x , knowing the value of R and of the ratio R_1/R_2 . R_x is equal to (*derive the following equations using Kirchhoff's laws*)

$$R_x = R \frac{R_1}{R_2}. \quad (1)$$

In this experiment, the resistors R_1 and R_2 are two parts of the potentiometer P. By adjusting the position of the slider, one can change the ratio R_1/R_2 . R_1 is proportional to the number of

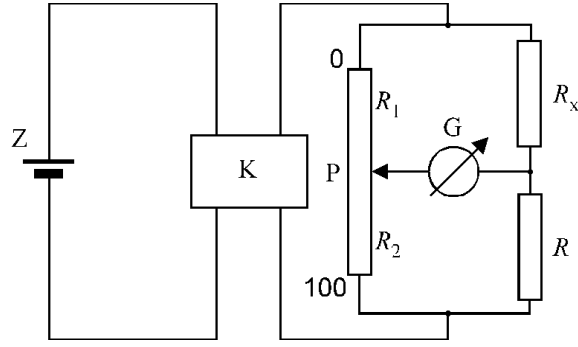

Figure 1: Diagram of the Wheatstone's bridge.

ticks n indicated by the slider position, while R_2 is proportional to $N - n$, where $N = 100$ is a total number of ticks in the potentiometer scale. Hence, Eq. (1) can be written as

$$R_x = \frac{n}{N - n} R. \quad (2)$$

By adjustment to the position of the potentiometer scale one can balance the bridge, so there is no current flowing through the galvanometer G.

The precision of the measurements can be increased if the resistance R is selected in such a way that the bridge is balanced for the potentiometer set somewhere near the middle of its scale. To prove this, consider the absolute error of R_x , derived from Eq. (2) (*show this derivation*)

$$\Delta R_x = R_x \left(\frac{\Delta R}{R} + \frac{N \Delta n}{(N - n) n} \right), \quad (3)$$

where $\Delta R/R$ is the relative error of R and is independent of the position of the slider, and Δn is the absolute error of the potentiometer. The fraction $\frac{N \Delta n}{(N - n) n}$ depends on n and reaches its minimum value if the denominator $(N - n)n$ achieves its maximum. To find it compute the derivative of the denominator

$$\frac{d}{dn} (nN - n^2) = N - 2n.$$

The extreme is reached if this derivative is equal to 0 (the second derivative is constant and always negative). Hence, error ΔR_x is the smallest one if $n = N/2$. In our case, this means that n should be as close to 50 as possible.

4 Measurements and results analysis

4.1 Measurements of single resistors

1. Connect all the elements according to the diagram shown in Fig. 1. Mind the unknown resistance R_x must be attached to the slot corresponding to "0" of the potentiometer P.
2. Ask the teacher, which unknown resistors should be examined, and connect the first of them.
3. Choose the best resistance R on the decimal resistor to minimise the error ΔR_x , according to the section 3.
4. Find the position n of the potentiometer that precisely balances the bridge. You can check the proper balance, by switching the direction of the current flow using the switch K (*what behaviour should be expected after the switch, for balanced and unbalanced bridge?*). Repeat the measurement several times, by moving the slider to some random position before each

of them. Determine the error Δn using Student's method (*how does it correspond to the resolution of the scale?*)

5. Repeat points 3-4 for other selected resistors. Caution! Always switch off the power before changing the resistors.

In your report you are expected to present the results together with their errors (you can assume $\frac{\Delta R}{R} = 0.05$). The determined resistances will be required to complete the second part of the experiment.

4.2 Measurements of multiple resistors

In this part of the experiment you are supposed to measure the equivalent resistance of several resistors connected in various ways. Propose some interesting connections of the resistors and discuss them with the teacher. Measure the resistance of the connected sets with a method shown in section 4.1 and present your results (together with errors) in your report. Next, compute the equivalent resistance of each set using the resistances of single resistors, measured in previous section. Compare the results of calculations with the experimental ones.